



Loving music

Double Matrix Professional

Double sided record cleaning machine

User manual



Made in Germany

Hi-Fi Components **clearaudio[©] electronic GmbH**

Spardorfer Str. 150 ● D-91054 Erlangen ● Tel. +49(0) 1805/059595 ● FAX +49(0) 09131/51683
www.clearaudio.de ● www.analogshop.de ● info@clearaudio.de / copyright clearaudio© 2011

Version 1.5_16.12.11_E



Double Matrix Professional

User manual

Dear clearaudio customer,

Congratulations on the purchase of your new **clearaudio** *Double Matrix Professional* record cleaning machine, an extraordinary product made by **clearaudio**.

The cleaning of dirty or used records improves the overall sound quality. This also applies to new vinyl records as there is often residue left over from the pressing process.

Please read this user manual with great care, to avoid misuse or void of warranty.

Why Double Matrix Professional?

Many analog and music lovers, as well commercial and professional organisations have asked us how it is possible to clean vinyl records both thoroughly and quickly, and if during the process placing the just-cleaned side of the record on the potentially dirty turntable can be avoided.

It is obvious when cleaning large numbers of records, especially under commercial circumstances, that time is money.

To achieve this goal **clearaudio** set about designing a semi-automatic record cleaning machine, that would, without costly accessories, perfectly clean both LPs and EPs - eliminate any electrostatic charge, avoid the need to flip the record over all within one minute. This required a revolutionary and outstanding product to be developed. An intensive research and development program led **clearaudio** to achieve not only these criteria but also the additional goals of efficiency, easy-of-use and longevity. The result: the **clearaudio** *Double Matrix Professional*.

Materials and craftsmanship

The **clearaudio** *Double Matrix Professional* is massively constructed from the highest grade of materials and components. The rigid housing is machined from 4.5 mm thick aluminium plates and the platter is made out of 10 mm thick aluminium. The corner poles, feet and the fluid tank are made out of very rigid materials. This contributes towards the substantial total weight of approximately 16.5 kg.

Thank you very much for choosing the **clearaudio** *Double Matrix Professional*.

The following pages will explain how to operate your **clearaudio** record cleaning machine correctly.

We wish you years of satisfaction from your new **clearaudio** *Double Matrix Professional*.

Directory

1. Package contents	4
2. Features overview	5
3. Set up	6
4. Operational controls and functions	7
5. Beginning of operation	11
6. Machine maintenance	13
7. Service information	16
8. Technical data	17
Warranty information	18

Important note!



Pic. 1: Warning

1. Package contents

The **clearaudio** *Double Matrix Professional* is delivered in bespoke packing. Please take the record cleaning machine out of the packing and place it on a safe and stable surface.

Please check if the *Double Matrix Professional* has suffered any damage in transit. Next gently remove the blue securing adhesive tape. Any adhesive residue from the tape can be easily rubbed off by hand.

Please keep the original packing, to avoid any unnecessary damage in case the machine needs to be transported.

Please check the package content of your *Double Matrix Professional* :

- 1. Complete pre-installed *Double Matrix Professional* machine**
- 2. Seal Clamp**
- 3. Filling funnel**
- 4. Power cord**
- 5. 4 pcs. spare microfibre strips**
- 6. 250 ml 'Pure Groove' cleaning fluid**
- 7. Cover for cleaning fluid reservoir**
(already installed)
- 8. Fluid release knob**
(already mounted on the rubber tube)
- 9. Single Adapter**
- 10. Warranty card ***
* see page 18 for warranty information.



Pic.2: Package contents

In the case that the contents are incomplete, please contact the **clearaudio** dealer, where you purchased the *Double Matrix Professional* .



2. Features - overview

⇒ Both sides cleaned at once

Due to the sophisticated design of the wash and vacuum arm tubes, it is now possible to clean both sides of your precious vinyl at once. This results in even higher convenience of use.

To ensure constant brush pressure a sophisticated magnetic mechanism is used.

⇒ Left-right turn switch

The best cleaning results from cleaning in both directions.

⇒ Continuously variable speed regulation

By allowing variable speed of rotation the dirtiest records can be cleaned at a slower speed preserving both the microfibre strips and your record.

⇒ Cleaning of LPs, EPs and Singles

The *Double Matrix Professional* is able to clean all these formats without any additional accessories.

You even do not need to change the cleaning vacuum arms for the different formats.

⇒ Excellent cleaning

The *Double Matrix Professional* cleaning process raises the audible improvements to a new level which regular cleaning machines do not reach. This is proven by our laboratories.

⇒ No platter

The vinyl records are not placed on any potentially dirty surfaces, instead being supported on a label-sized platform. The integrated cleaning and vacuum brushes stabilise the vinyl disc during the cleaning process and the record labels are completely protected both above and below by two of the highly regarded **clearaudio** Seal Clamps.

⇒ Cleaning in half of the time

Both sides of any record are cleaned at once. This reduces the time of the cleaning process by least 50%. Especially in commercial use, this is an unbeatable advantage.

⇒ Integrated filter

To avoid contamination by any dust or other particles, there is a micro filter integrated, ensuring a long life for the cleaning brushes and your vinyl.

⇒ Ease of use

The cleaning process as well as any maintenance are particularly easy and customer-friendly.

⇒ Perfect cleaning fluid control

Only the fluid that is required will be dispensed. This is achieved by two electronically controlled magnetic valves, which ensure that no fluid is able to transfer while vacuuming. You will find other machines on the market where this is not the case.

⇒ Antistatic brush

The high efficiency antistatic brush completely discharges static and may be used even if you do not want or need to clean your record. The sonic benefits are obvious.

⇒ Noise reduction

The *Double Matrix Professional* is equipped with acoustic damping material for reduced noise levels during use.

3. Set up

Place the *Double Matrix Professional* on a stable surface such as a table or rack. Please note that due to the weight of the *Double Matrix Professional* it could damage soft surfaces, or through movement of the *Double Matrix Professional* the surface could suffer scratches. Please make sure that the surface is able to withstand temperatures up to 60°C.



3.1 Connection with main power

Connect the supplied power cord first to the IEC connector at the rear panel of the *Double Matrix Professional* then connect it to the power outlet. **Please make sure that the appropriate connector is used and that the voltage is correct.** Please refer to the type sticker next to the IEC connection.

The best results will be achieved when the *Double Matrix Professional* is used in a room temperature of between 15°C and 30°C.



Pic.3: Rear view



Pic.4: Connection

3.2 Switch On

Next to the IEC connector is the mains power switch (pic. 4). When the unit is switched on the red light of the switch is illuminated.

Make sure that the appropriate connector is used and that the voltage is correct!

Now your *Double Matrix Professional* is ready to be used.

Please first finish reading the whole manual!

4. Operational controls and functions

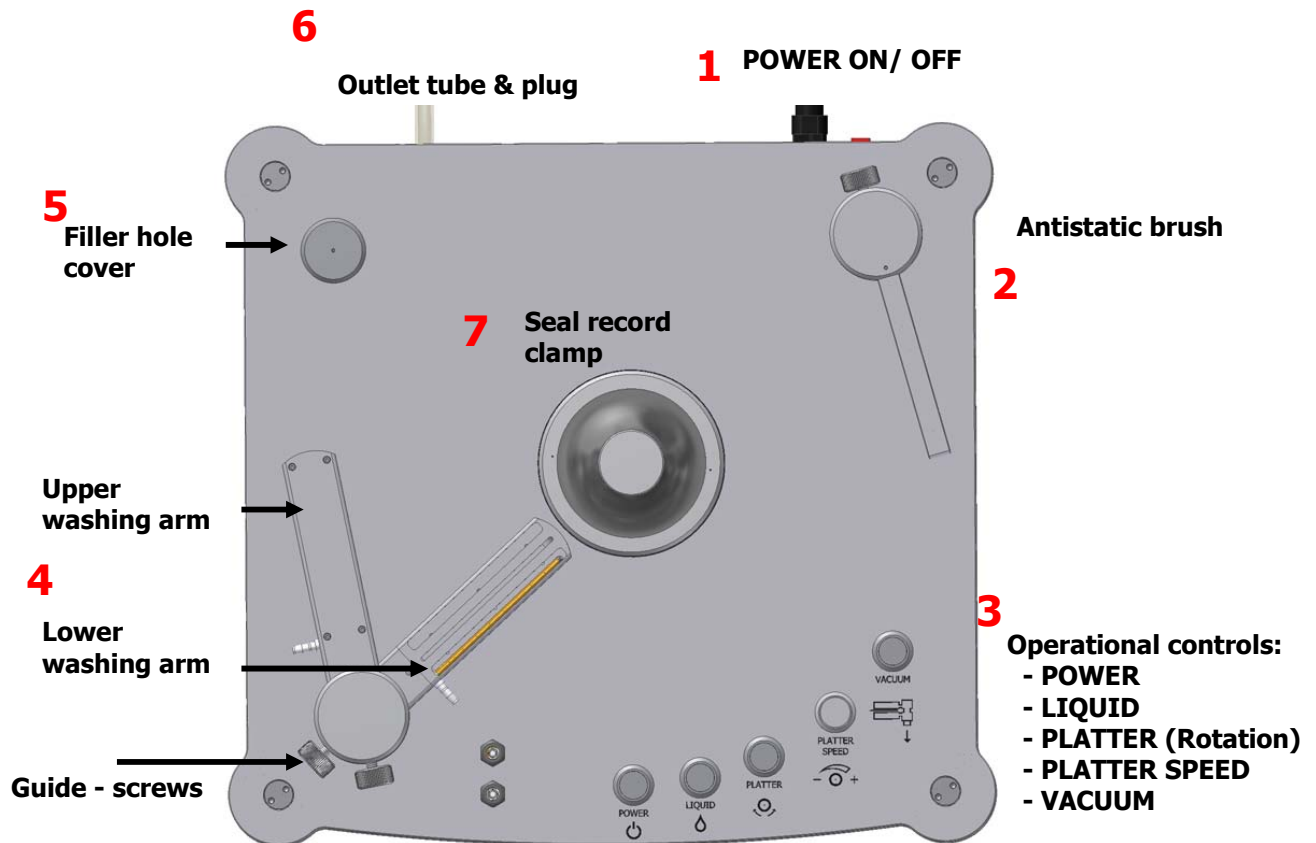

Pic.5: Top view

Please familiarize yourself with all the operational controls which are described in detail over the following pages.

1

Power connection on the rear panel

For switching on and off. If the unit is switched on the red light of the switch is illuminated.

If the machine is not in use for any lengthy period, please switch it off at the rear panel.

2 Antistatic brush

The antistatic brush (Pic. 6) is used to discharge any electrical charge that may be present already, or can be generated while cleaning. After vacuuming, make sure that the record surface is completely dry, then place the antistatic brush in position by rotating it clockwise (towards the record). Leave it in place for at least one complete revolution.

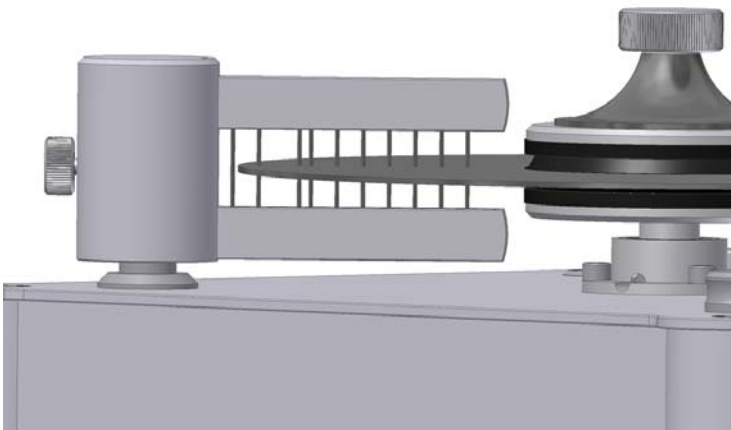

Pic.6: Use of Antistatic brush

This Function can be used to remove static even if you did not clean the record. If the hairs of the carbon fibre brush do not make good contact with the record surface, use a comb to place the carbon hairs back in position.

3 Operational controls



Pic. 7: Operational controls

POWER = Starts and stops the *Double Matrix Professional*

LIQUID = Automatically applies fluid via the washing arms

PLATTER = Clockwise / anticlockwise rotation of the platter

PLATTER SPEED = Continuously variable speed regulation of the platter for selective cleaning

VACUUM = Activate the removal of the fluid

4

Upper and lower cleaning arms

The upper and the lower cleaning arms perform the functions of cleaning fluid dispensing, cleaning and vacuuming. When the upper cleaning arm is in its working position (pic. 9) there is always a constant pressure on the record. In the rest position (pic. 8) the upper and the lower cleaning arms are automatically retracted from the record. The upper cleaning arm (pic. 10) can be rotated 90° to be placed parallel to the lower cleaning arm. The lower cleaning arm cannot be moved. It automatically raises to the operating position by the magnetic mechanism.

On each side of the lower cleaning arm (pic. 10) you see the fluid drains. These provide built in protection against fluid dripping if too much fluid is used while cleaning. This fluid will be automatically run through the blue tube back into the reservoir.

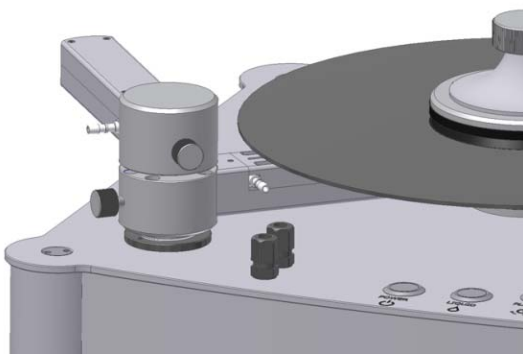

Pic. 8: Rest position

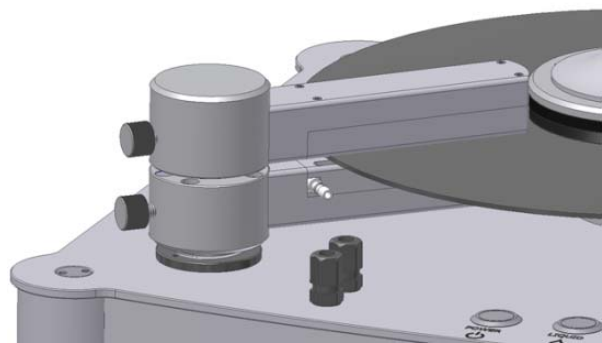

Pic. 9: Working position

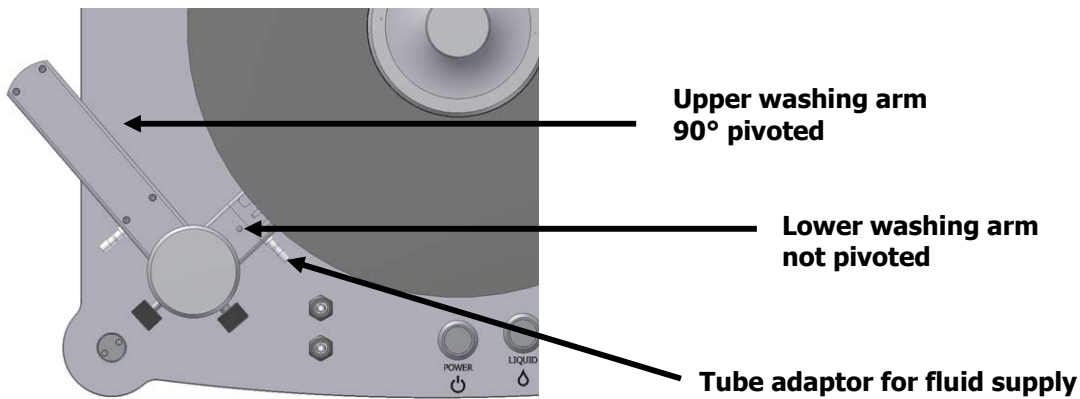

Pic. 10:Washing arm

5

Cover filler hole

Using the supplied funnel, carefully fill the fluid reservoir with **clearaudio** "Pure Groove" record cleaning fluid.

6

Outlet tube & plug

By pulling out the plug you can empty the used cleaning fluid out of the fluid tank (see page 14).

7

clearaudio "Seal" record clamp

The **clearaudio** "Seal" record clamp (pic.11) has been developed to cover and protect the record label and to hold the records securely.

On the outer aluminium ring you will find two small vacuum release holes. This makes it easier to release the clamp after the cleaning process.

Important!

Please place the "Seal record clamp" with some pressure on the record in order to avoid any unwanted sliding of the record!

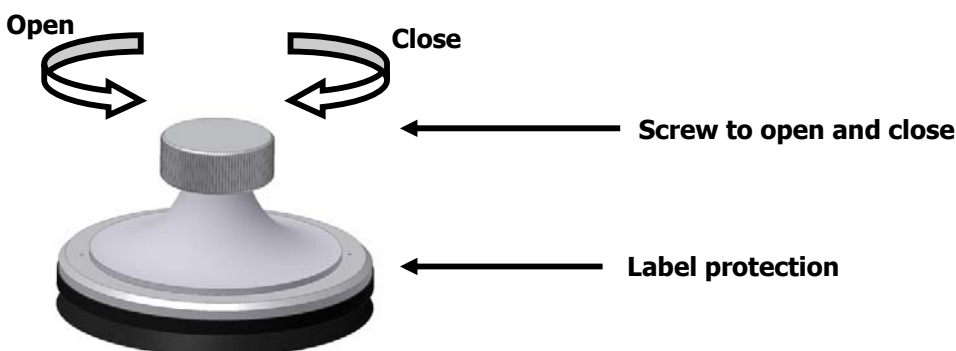

Pic. 11:Seal record clamp

5. Beginning of operation

5.1 Cleaning fluid reservoir filling

We recommend only using **clearaudio** "Pure Groove" cleaning fluid for perfect results and for the safety of your records (available from: www.analogshop.de).

Attention:

Foaming fluid can damage the machine and void the warranty!

The cleaning fluid reservoir has a maximum capacity of **0.35 litre**. Open the fluid reservoir by removing the round cover. Using the supplied funnel, carefully fill the reservoir. There is no need to worry if you over-fill the tank, just wipe the excess fluid off with a cloth.

5.2 Record cleaning, vacuum drying, electrostatic discharging

For the very first record cleaning process we recommend that you use a defective or very used record in order to become familiar with the machine.

1. Remove the record clamp by twisting the lock cap anticlockwise (pic. 11, page 10). Place the record over the spindle and replace the record clamp. Tighten it firmly, so that the record cannot slip while vacuuming.
2. Position the upper arm over the record by swinging it clockwise 90°. Press down lightly the upper cleaning arm so that the upper and lower cleaning arms will be magnetically attracted together.
3. By pressing the button "LIQUID" the rubber tubes will fill up with the cleaning fluid. Wait until the fluid comes out of the cleaning arms onto the upper and lower surface of the record. The micro fibre brushes should be wet before switching on the platter.

**Important: Press the "LIQUID" button for a maximum of one turn.
Do not press the button again!**

4. To start the platter revolving push the "POWER" button. By using the "PLATTER SPEED" control you can vary the speed of the platter and therefore the cleaning process of your record. The combination of quantity of fluid dispensed and speed of revolution should be adjusted so that the fluid should form a complete unbroken surface across the record

5. Depending on the dirtiness of the record, let the platter rotate 3 to 5 times in each direction.

Caution: Please ensure that there is enough fluid on the record surface.

For a very intense cleaning, you can stop the platter during the cleaning process and wait 30 to 60 seconds for the fluid to fully absorb any contaminants.

5.3 Vacuum drying

6. To achieve a perfect result, proper vacuuming is necessary. Press the "VACUUM" button to start the vacuum drying process.

7. When the record is dry always switch off the vacuum first, then pull the upper cleaning arm upwards and swing it back to the left to its rest position.
Finally stop the platter using the "POWER" button.

Important!

**The cleaning arm should always be placed back in its rest before stopping the platter.
After vacuum drying never change the platter direction.**

8. Position the antistatic brush over the record by lifting the brush up and swinging it towards the record. Let the platter turn at least one more complete revolution.

You should do this procedure after every cleaning process.
After the antistatic procedure place the antistatic brush back in its rest position and switch off the platter.

Never use the antistatic brush when the record is wet!

Now you can remove the record and enjoy a cleaner window to the music.

5.3 Further care instructions

1. Never use the antistatic brush on wet records.
2. Dust and dirt will build up on the microfibre strips and should be removed after every use. We recommend using a clean and soft cloth.
3. Please change the microfibre strips at regular intervals, especially if you use the machine very often.



6. Machine maintenance

6.1 Changing the microfibre strips

This procedure will be easier if you remove the upper cleaning arm .

Releasing the upper cleaning arm

First take the rubber tube off of the upper cleaning arm (pic. 12, no.1).

Now release the positioning screws by turning them anticlockwise until they stand 5 - 8mm further out of the housing. It is not a problem if you release the screws completely (pic. 12, no.2).

Now you can take off one or both cleaning arms. (pic. 12, no. 3)

To prevent any scratches, place them on a soft surface.

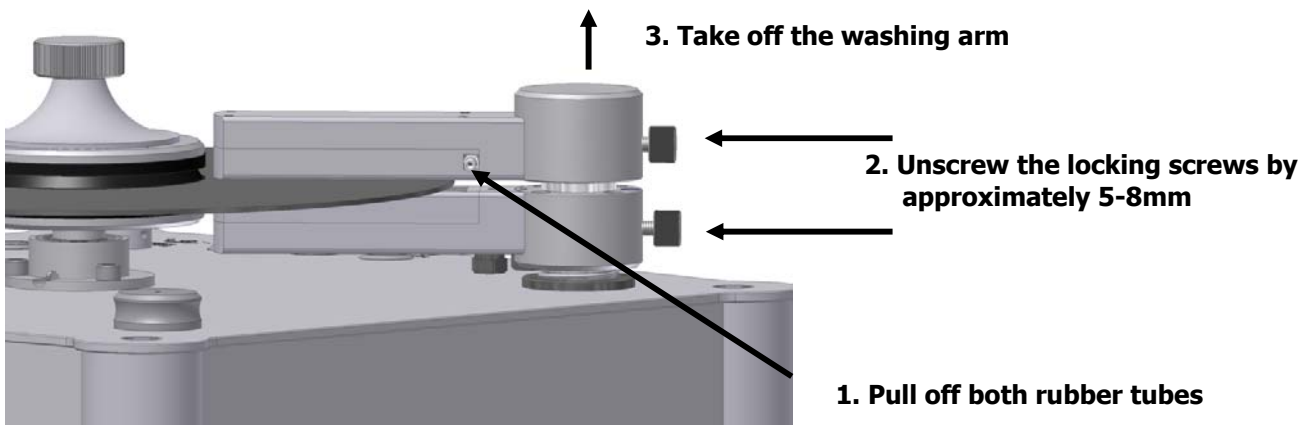

Pic. 12: Washing arms

Before removing the old microfibre strips, carefully note their exact position on the cleaning arms. The adhesive surface must be clean and dry.

Remove the protection foil, place the new microfibre strips in position and press the gently onto the cleaning arms.

Attention!

Do not place the strips over the small fluid dispensing holes.

After changing the microfibre strips reinstall the cleaning arms by reversing the process described above.

6.2 Self-cleaning procedure

Depending on the dirtiness of the records after cleaning several records you should clean your cleaning arms as dust and dirt may lessen the cleaning performance.

Place the upper cleaning arm in the working position over the lower one.

Attention!

Do not place a record onto the machine while the self-cleaning process.

6.3 Waste fluid tank

The waste fluid tank has a capacity of 0.75 litre, which should allow 100 records to be cleaned before it needs emptying. Of course this depends on the amount of fluid used for each cleaning. If you clean more than 20 records in one day you should also empty the waste fluid tank.

6.4 Draining and cleaning of the waste fluid tank

Draining the waste fluid tank

Place a suitable container on the floor for the waste fluid. Remove the cap from the rubber tube at the rear of the machine and place the tube into the disposal container. Tilt the machine towards the back (about 45°) until the fluid drains out of the tube.

Attention!

The rubber tube should only be opened for fluid release! When finished, always securely place the cap back on the tube!

Do not reuse the drained fluid!

Cleaning the waste fluid tank

Remove the upper cleaning arm and pour the cleaning fluid into the stainless steel tube. A mixture of water and vinegar works well.

Attention!

During the cleaning process, never switch on the vacuum!

Before releasing the rubber tube, let the fluid rest in the tank for about 20 minutes.



Pic. 13 Rubber tube seal / lock

Draining the cleaning fluid reservoir

If your *Double Matrix Professional* ever needs to be transported please make sure that there is no fluid left in it at all.

Therefore it may be necessary to empty both the waste fluid tank and cleaning fluid reservoir. Pull off the two rubber tubes from the cleaning arms and place them into a suitable container. Push the "LIQUID" button allowing the fluid to drain completely into the container until there is no fluid left. Push the rubber tubes back onto the cleaning arms.

If you do not use the machine for a long period we recommend draining both the waste fluid tank and cleaning fluid reservoir!



Double Matrix Professional

User manual

7. Service information

The warranty period for the *Double Matrix Professional* is two (2) years.

You can achieve the extended warranty time of three (3) years, if you fill out the warranty card and send it in within 2 weeks after purchase, to the following address:

clearaudio electronic GmbH
Spardorfer Str. 150
91054 Erlangen
Germany

Please note, never use foaming or acid-based fluids!
Use always special clearaudio "Pure Groove" fluid. Otherwise the warranty will be void.

The *Double Matrix Professional* should only be repaired by clearaudio or approved institutions or persons, otherwise the warranty will be void.

For your own safety a frequent visual check of the mains cables is advised. If any damage should occur, the repair or exchange should be done immediately through an approved electrician or institution!

Any service of clearaudio products should be done only by certified clearaudio dealers.

If damage of the machine should occur for any reason and a repair of the machine is necessary then it should be sent to the selected dealer, distributor or directly to :

clearaudio electronic GmbH
Spardorfer Str 150
91054 Erlangen
Germany

Tel/Phone: +49-(0)9131 / 57702
www.clearaudio.de
www.analogshop.de
info@clearaudio.de

If you transport or ship the *Double Matrix Professional*, the use of original packaging is required! Please pack the machine like it has been packed originally from **clearaudio**. Only in the original packaging a secure transport is possible.

Legal disclaimer :

Clearaudio refuse to cover any claims or damage to records or any other damage that have been caused by misuse or mishandling of the *Double Matrix Professional*.

8. Technical Data

Construction:	The <i>Double Matrix Professional</i> is a fully automatic record cleaning machine, turning the platter left and right, including vacuum suction.
Weight:	approx. 16.5 kg
Dimensions (LxWXH): Total height:	410 mm x 385 mm x 175 mm 265 mm (incl. record clamp)
Warranty:	3 years, if the warranty card is filled out correctly and send back to clearaudio within 2 weeks
Total Power consumption:	500 Watts
Noise Level:	approx. 60 – 65 db
Further accessories:	Dust cover (Art. No. AC127) "Pure Groove" record cleaning fluid (Art. No. AC084) available at: www.analogshop.de

Attention:

This unit is for indoor use only!
Never place flammable goods near or onto the machine!
This unit / machine was built to be used in heated or climatic controlled surroundings.
Never touch the power cord with wet hands or other wet body parts !
Never put or use any equipment with open flames, like candles on top of this equipment!

CE The **clearaudio** *Double Matrix Professional* is approved according to the regulations of the CE certification and other international standards and approvals.

clearaudio electronic is not responsible for typographical errors in descriptions. Technical specifications subject to change or improvement without prior notice. Availability as long as stock lasts. Copies and imprints- also only in extracts – require written conformation through **clearaudio** electronic GmbH; Germany
© clearaudio electronic GmbH 2011

Version: December 2011



Double Matrix Professional

User manual

To achieve the full **clearaudio** warranty, it is necessary that you fill out and send the corresponding part of the warranty registration certificate /card back to clearaudio, within two weeks after purchase. Only if the product is returned in it's original packing clearaudio can provide the warranty of 3 years. Otherwise clearaudio provides the legal warranty of 2 years.

ENGLISH **WARRANTY**

For warranty information, contact your local clearaudio distributor.

RETAIN YOUR PURCHASE RECEIPT

Your purchase receipt is your permanent record of a valuable purchase.

It should be kept in a safe place to be referred to as necessary for insurance purposes or when corresponding with clearaudio.

IMPORTANT

When seeking warranty service, it is the responsibility of the consumer to establish proof and date of purchase. Your purchase receipt or invoice is adequate for such proof.

FOR U.K. ONLY

This undertaking is in addition to a consumer's statutory rights and does not affect those rights in any way.

FRANÇAIS

GARANTIE

Pour des informations sur la garantie, contacter le distributeur local clearaudio.

CONSERVER L'ATTESTATION D'ACHAT

L'attestation d'achat est la preuve permanente d'un achat de valeur. La conserver en lieu sûr pour s'y reporter aux fins d'obtention d'une couverture d'assurance ou dans le cadre de correspondances avec clearaudio.

IMPORTANT

Pour l'obtention d'un service couvert par la garantie, il incombe au client d'établir la preuve de l'achat et d'en corroborer la date. Le reçu ou la facture constituent des preuves suffisantes.

DEUTSCH

GARANTIE

Bei Garantiefragen wenden Sie sich bitte zunächst an Ihren clearaudio-Händler.

Heben Sie Ihren Kaufbeleg gut auf.

WICHTIG!

Die Angaben auf Ihrer Quittung erlauben uns die Identifizierung Ihres Gerätes und belegen mit dem Kaufdatum die Dauer Ihrer Garantie-Ansprüche.

Für Serviceleistungen benötigen wir stets die Gerätenummer.

Diese finden Sie auf dem Typenschild auf der Rückseite des Gerätes oder auch in der beigelegten Garantie-Registrierkarte.

NEDERLANDS

GARANTIE

Voor inlichtingen omtrent garantie dient u zich tot uw plaatselijke clearaudio.

UW KWITANTIE, KASSABON E.D. BEWAREN

Uw kwitantie, kassabon e.d. vormen uw bewijs van aankoop van een waardevol artikel en dienen op een veilige plaats bewaard te worden voor evt, verwijzing bijv, in verband met verzekering of bij correspondentie met clearaudio.

BELANGRIJK

Bij een evt, beroep op de garantie is het de verantwoordelijkheid van de consument een gedateerd bewijs van aankoop te tonen. Uw kassabon of factuur zijn voldoende bewijs.

ITALIANO

GARANZIA

L'apparecchio è coperto da una garanzia di buon funzionamento della durata di un anno, o del periodo previsto dalla legge, a partire dalla data di acquisto comprovata da un documento attestante il nominativo del Rivenditore e la data di vendita. La garanzia sarà prestata con la sostituzione o la riparazione gratuita delle parti difettose.

Non sono coperti da garanzia difetti derivanti da uso improprio, errata installazione, manutenzione effettuata da personale non autorizzato o, comunque, da circostanze che non possano riferirsi a difetti di funzionamento dell'apparecchio. Sono inoltre esclusi dalla garanzia gli interventi inerenti l'installazione e l'allacciamento agli impianti di alimentazione.

Gli apparecchi verranno riparati presso i nostri Centri di Assistenza Autorizzati. Le spese ed i rischi di trasporto sono a carico del cliente. La casa costruttrice declina ogni responsabilità per danni diretti o indiretti provocati dalla inosservanza delle prescrizioni di installazione, uso e manutenzione dettagliate nel presente manuale o per guasti dovuti ad uso continuato a fini professionali.

ESPAÑOL

GARANTIA

Para obtener información acerca de la garantía póngase en contacto con su distribuidor clearaudio.

GUARDE SU RECIBO DE COMPRA

Su recibo de compra es su prueba permanente de haber adquirido un aparato de valor. Este recibo deberá guardarlo en un lugar seguro y utilizarlo como referencia cuando tenga que hacer uso del seguro o se ponga en contacto con clearaudio.

IMPORTANTE

Cuando solicite el servicio otorgado por la garantía el usuario tiene la responsabilidad de demostrar cuándo efectuó la compra. En este caso, su recibo de compra será la prueba apropiada.